

TMC4671 BOB Description

Document Revision V1.2 • 2020-Apr-10

Module Top View

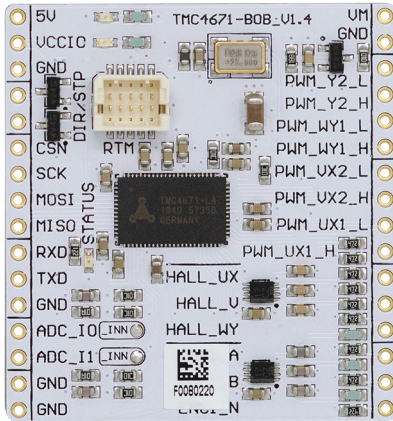

Pin List

Left	Signal	Right	Signal
1	+5V	17	VM (0...80V)
2	VCCIO (3.3V)	18	GND
3	GND	19	PWM_Y2_L
4	STP	20	PWM_Y2_H
5	DIR	21	PWM_WY1_L
6	CSN	22	PWM_WY1_H
7	SCK	23	PWM_VX2_L
8	MOSI	24	PWM_VX2_H
9	MISO	25	PWM_UX1_L
10	RXD	26	PWM_UX1_H
11	TXD	27	HALL_UX
12	GND	28	HALL_V
13	ADC_IO	29	HALL_WY
14	ADC_I1	30	ENC1_A
15	GND	31	ENC1_B
16	GND	32	ENC1_N

Features and additional Resources

- TMC4671-LA Hardware Servo Controller
- Supply and I/O voltage 3.3V and 5V (with blue LED indicator)
- Motor supply voltage input to measure motor supply (0...80V)
- Communication and configuration via SPI and UART interface
- Real-time Monitoring Interface for live debugging and tuning using [Trinamic's RTMI adapter](#)
- Additional Step/Direction Interface from a motion controller
- Encoder- and Hall-Feedback
- Supply and status indicator LEDs
- Board width 1.5", board height 1.6"
- 2x16 pin 0.1" header rows for pins/connectors, distance of rows 1.4"
- Link to [additional information and IC data sheet](#)
- Link to [evaluation kit](#)

RTMI Connector

The real-time monitoring interface connector is used to connect to [Trinamic's RTMI adapter](#) for live monitoring and tuning of the TMC4671 control loops at control loop sampling frequency.

The onboard connector itself is of type [Hirose DF20F-10DP-1V\(56\)](#).

The mating female counter part is of type [Hirose DF20A-10DS-1C](#). A connecting cable comes with the USB-2-RTMI adapter.

Left	Signal	Right	Signal
1	+3.3V	2	n.c.
3	DBG_SPI_nSCS	4	DBG_SPI_TRG
5	DBG_SPI_SCK	6	GND
7	DBG_SPI_MOSI	8	GND
9	DBG_SPI_MISO	10	GND



Bill of Materials

Pcs.	MPN	Value	Footprint	Description
11	MC0603B104K100CT	100nF, 10V	0603	Cap, Multicomp
5	MC0603N101J500CT	100pF, 50V, 5%	0603	Cap, Multicomp
1	MCSH18B103K100CT	10nF, 10V	0603	Cap, Multicomp
1	GRM31CR61A476ME15L	47uF, 10V	1206	Cap, Murata
1	MC0603B104K100CT	100nF, 10V	0603	Cap, Multicomp
1	MC0603X474K160CT	470nF, 16V	0603	Cap, Multicomp
1	MC0603X475K100CT	4.7uF, 10V	0603	Cap, Multicomp
1	LTST-C191KRKT	$V_f = 2V @ I_f = 20mA$	0603	LED, Lite-On
3	BAT54S	30V, 200mA	SOT95P237X130-3N	SS Schottky, Taiwan Semiconductor
2	LTST-C191TBKT	$V_f = 2.8V @ I_f = 20mA$	0603	LED, Lite-On
1	TMC4671-LA	Integrated Servo Controller IC	QFN40P1050X650X90_HS-77N	TRINAMIC Motion Control
2	SN74LVC3G17DCUR	triple schmitt trigger, 1.65V-5.5V	TSSOP50P310X90-8L	Texas Instruments
1	MFB-160808-0030PQ	30R	0603	MECMARCOM
1	DF20F-10DP-1V(56)	Wire-2-board header, 1mm pitch, 10pins,	DF20 series, SMD	Hirose Electric Co Ltd
6	MC0063W0603110K	10k	0603	Res, Multicomp
1	MCWR06X1201FTL	1k2	0603	Res, Multicomp
5	MCWR06X1001FTL	1k, 1/10W, 1%	0603	Res, Multicomp
9	WR06X4701FTL	4k7, 1/10W, 1%	0603	Res, Walsin
2	MCWR06X1000FTL	100R	0603	Res, Multicomp
1	MCWR06X1501FTL	1k5	0603	Res, Multicomp
1	MCWR06X1003FTL	100k	0603	Res, Multicomp
1	FOX924B-25.000	25MHz, 2.5ppm, 3.3V	4-SMD, no lead	Oscillator, FOX Electronics

BOB Schematics

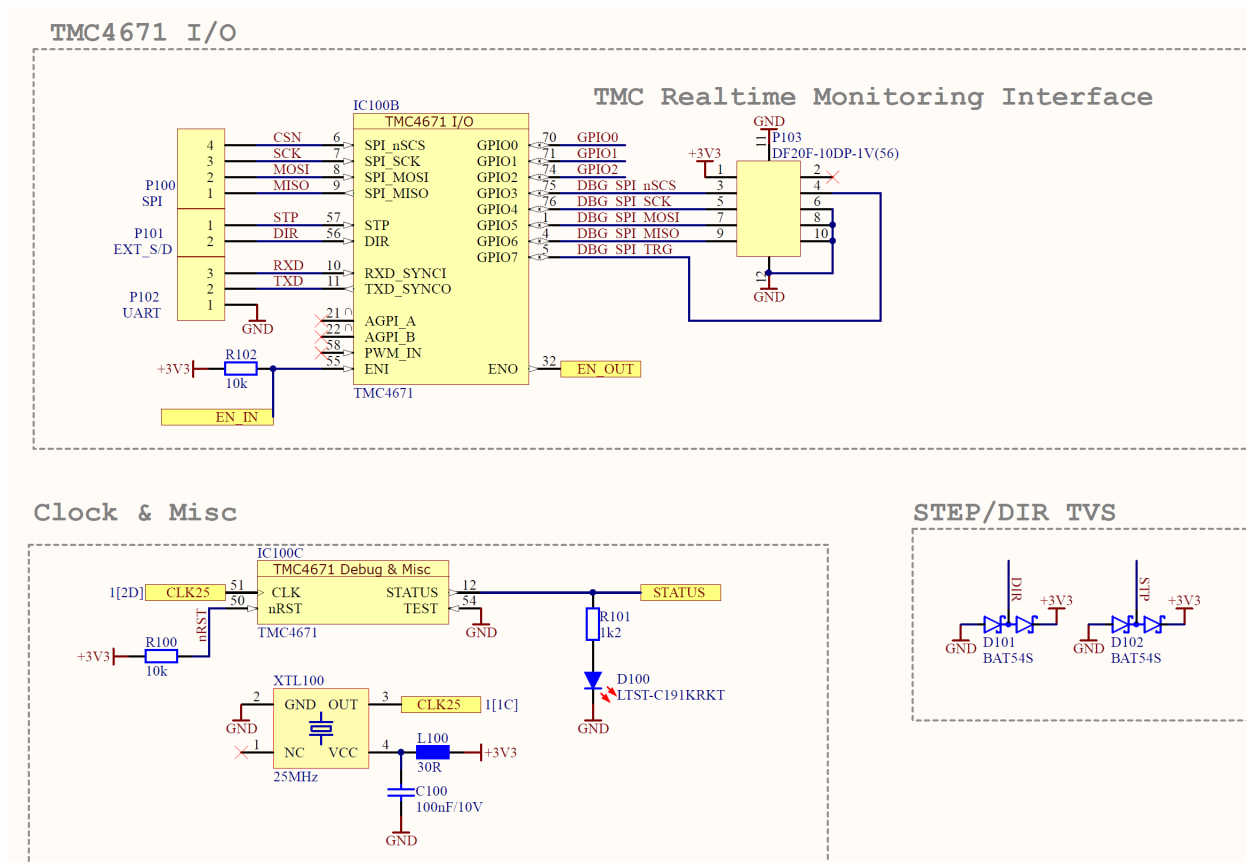

BOB Schematics

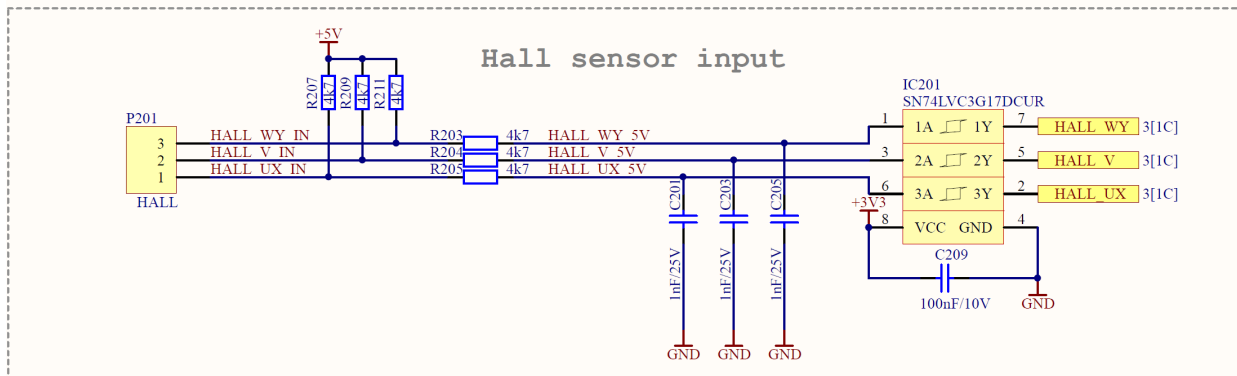
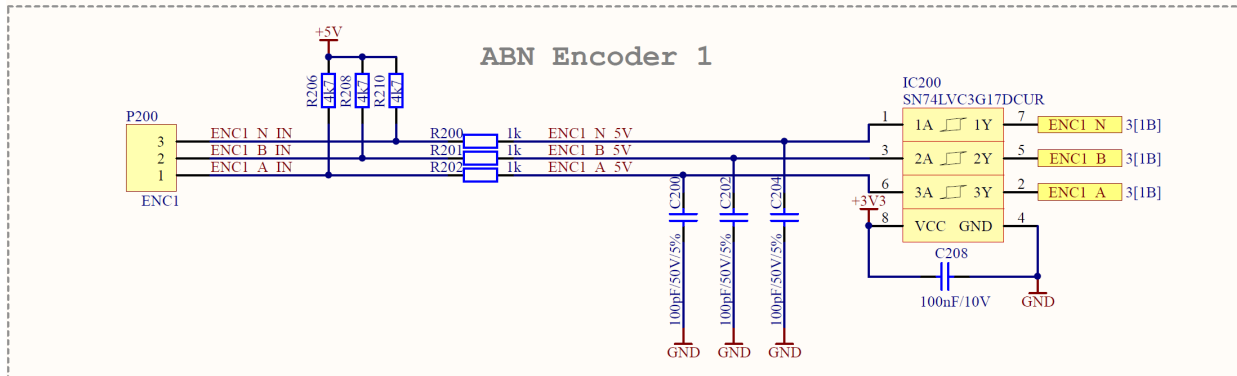

TMC4671 Sensing & Output

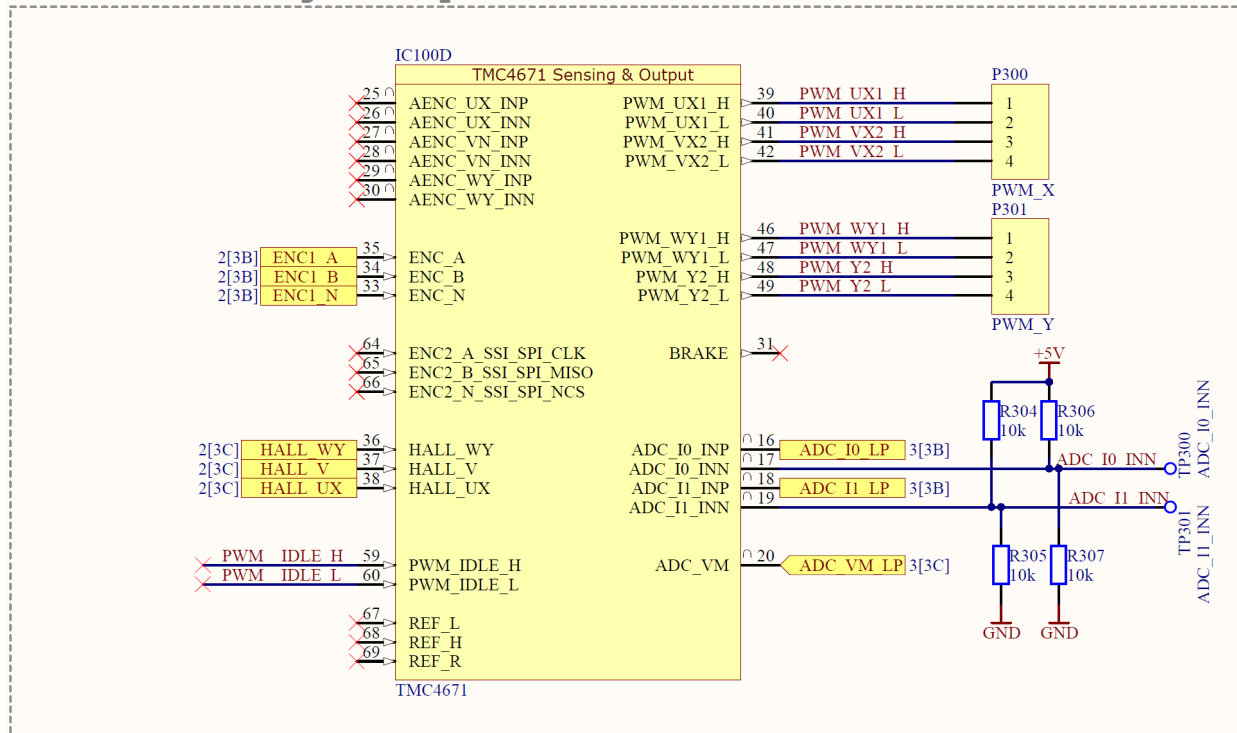

BOB Schematics

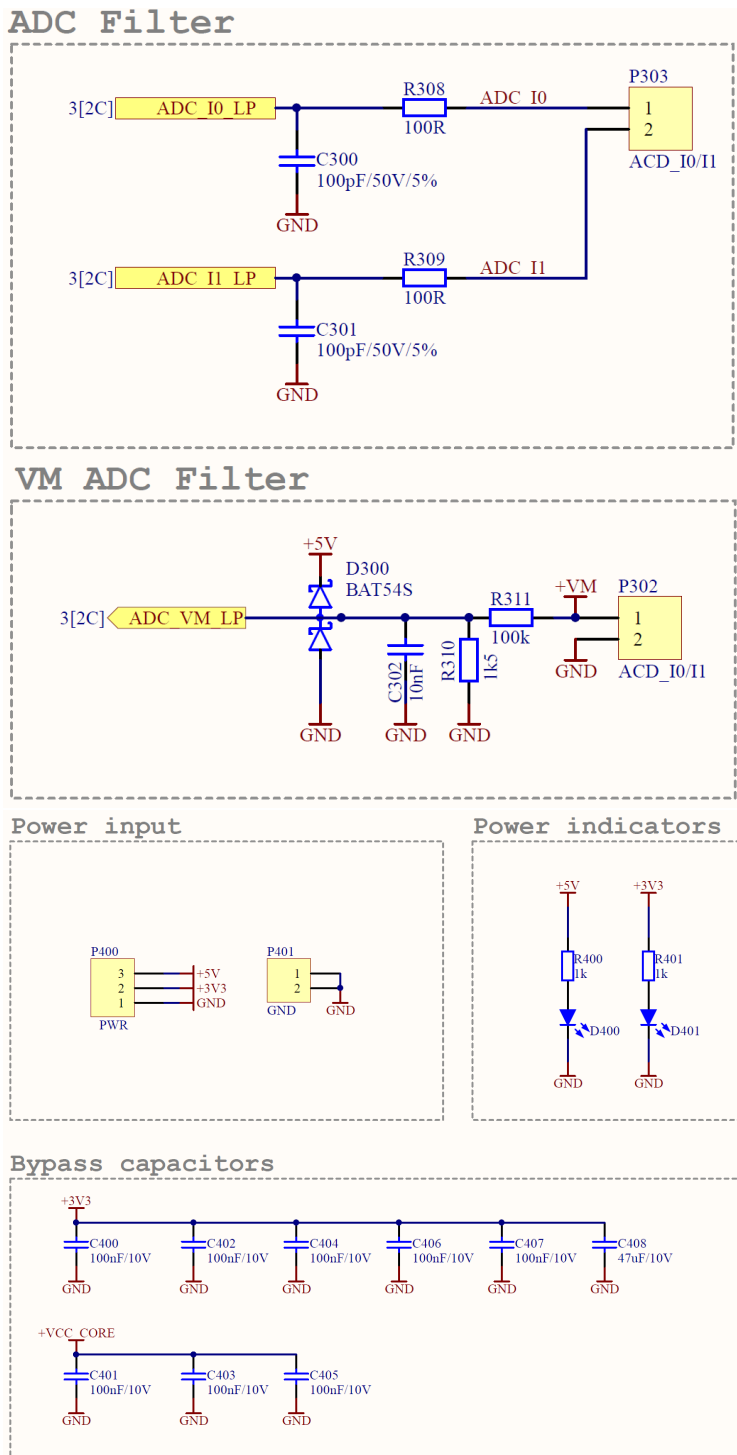

BOB Schematics

